

User guide for pump series CZA05, CZB05, CZA2, CZB2

N 10/2015

Universally

This user guide is for pump series 4CZA3, 4CZB3. It contains instruction for installation, use and maintenance. It is essential that all work in the transportation, installation, integration into the operation and maintenance by a **qualified, responsible and professional staff**.

Safety

Before connecting the pump to the power network is necessary to ascertain whether that is not under stress and that is protected against accidental switching on.

The terminal must not be foreign objects, dirt and moisture.

After prolonged use, the device can occur heat the surface of the stator and touching can occur burns.

Transport and storage

When you transporting pumps, you must protect it before damage. Store the pump in a dry environment.

Specification of product

This series pumps are gear pumps. They are designed for pumping and transport of oil with a viscosity up to $115 \text{ mm}^2\text{s}^{-1}$. **These pumps must not draw any flammable or volatile substances and must not work in explosive environments.**

Motors of these series pumps correspond to the standards EN60034 (IP54 rating). If on the rating label says otherwise, the motors are rated for ambient temperatures from -15°C to $+60^\circ\text{C}$ and the installation height of up to 1000m above sea level

The values shown in the table below are collected for kinematic viscosity $1 \text{ mm}^2\text{s}^{-1}$.

Technical data

	4CZA05 4CZB05	4CZA2 4CZB2
Protective power (for 400V) [A]	0,31	0,35
Maximum operating pressure * [kPa]	~ 600	~ 800
Maximum operating flow * [l/min]	~ 45	~ 70
Min. operating flow * [l/min]	~ 0,15	~ 0,5
Intake height (by immersion) [cm]	max. 250	max. 250
Kinematic viscosity [mm ² /s]	max. 115	max. 115

* Values are dependent on the viscosity of the pumped liquid. Protection against overload pump provides locking power control and set screw of the safety valve manufacturer on the value of the maximum operating pressure by the table above.

Voltage values:

Třífáz. varianta motoru 3x 400 V (380-420 V) 50Hz/60Hz

Installation

- Before installation make a careful inspection the pump and remove any defects professional manner.
- Pumps are designed for vertical installation (series 4CZA) or horizontal installation (series 4CZB) with flange to the tank with the pumped liquid. They are connected securely using four screws M6 pitch of 115 mm.
- Hydraulic intake hole cover must be at least 25 mm above the bottom of the tank to prevent suction of sediment.
- Minimum height of the liquid level must be above the intake tube, maximum level 20 mm below the seating surface of the mounting flange (4CZA) or 20 mm below the axis of the pumps (4CZB).

Put into operation

- When you connecting the pump to the electricity grid is necessary to comply with the requirements of applicable regulations and standards, especially ČSN 33 2000-4.41 and 5.54..
- All work on the pump motor is limited to qualified persons when the engine is off and secured against reconnection.
- You must pay attention to details of the power plate and connection diagram in the terminal.
- After connection the terminal to the suction's cable and cover terminal's cover, you must let the engine run and check the rotation of the rotor. Correct rotation is left when you viewed from above the motor (because the rotor is freely visible, and therefore the wrong direction detect just the absence of hydraulic power). In the case of incorrect direction of rotation the motor terminal can re-pole. The terminal cover can be rotated to any position at 90 degrees.

End of operation

- You must disconnect device from electrical distribution.
- You must remove the terminal cover and disconnect the wires.
- You must unscrew and remove pump from tank.

Maintenance

Pumps does not need any special maintenance. In operation you have to pay attention to the pump did not work "dry" because pumped liquid also provides prevention against seizing hydraulic parts and partially cooling.

Service

Another possible repairs performed by the manufacturer.

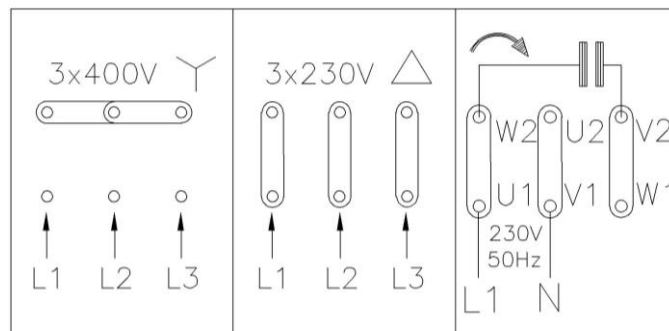

List of basic parts

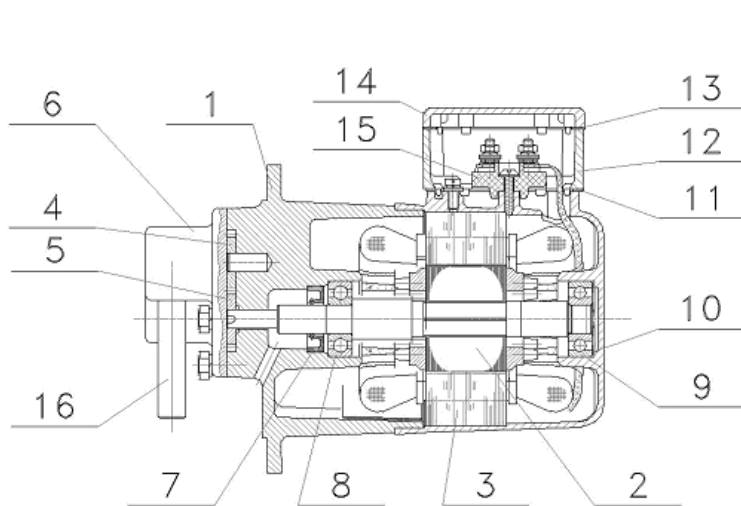

- 01 BODY CHAMBER (alloy Al)
- 02 ROTOR WITH SHAFT (steel, Al)
- 03 STATOR COMPLETE (alloy Al, Cu, steel)
- 04 DRIVEN COGWHEEL (grey cast iron)
- 05 DRIVE COGWHEEL (steel)
- 06 COVER OF CHAMBER (grey cast iron)
- 07 SHAFT SEALIN RING (rubber)
- 08 BEARINGS UPPER (6203 2Z)
- 09 BEARING LOWER (6201 2Z)
- 10 WASHER EQUALIZING (steel)
- 11 GASKET UNDER CASE (rubber)
- 12 CASEOF TERMINAL (alloy Al)
- 13 GASKET UNDER COVER (rubber)
- 14 COVER OF TERMINAL (alloy Al)
- 15 TERMINAL (plastic)
- 16 OVERFLOW PIPE (steel)

Removal

Any liquidation of this product and its individual parts must be made in a manner friendly to the environment for companies this purpose.

Kind of waste	Code	Categ.	Means of treatment
Waste from Elektor. A electron. Equipment-discarded devices.	16 02 14	O	Other waste-usable waste-sorting needs to be transmitted by an authorized person conducting the purchase of waste or secondary raw materials.
Paper and / or cardboard packaging	15 01 01	O	
Other discarded equipment, metal parts of pumps (without residuals oil)	17 04 07	O	
Other discarded equipment, no-metal parts of pumps (eg carbon, carbide, ceramics)	16 02 16	O	Other waste-to be collected and provide the operator dumps
Other discarded equipment, pumps, rubber parts	16 02 16	O	
Wooden package	15 01 03	O	Other waste to be collected and send for disposal in a waste incinerator
Plastic package film made of PE	15 01 02	O	
Small plastic items ²⁾	16 02 16	O	
Other engine, gear or lubrication oil	13 02 08	N	Hazardous waste must be collected and send for disposal to the authorized person
Other solvents and their mixtures with preservatives (including biodegradable)	14 06 01	N	
	14 06 02 14 06 03		

2) Beware of polytetrafluoroethylene (Teflon, PTFE) must not be due to the toxicity of burning gases other than in the incinerator.



EMP s.r.o.
Nádražní 394, 684 01 Slavkov u Brna

tel.: 544 423 020
544 423 021
fax: 544 221 828
e-mail: odbyt@emp-slavkov.cz